

L0603312.01

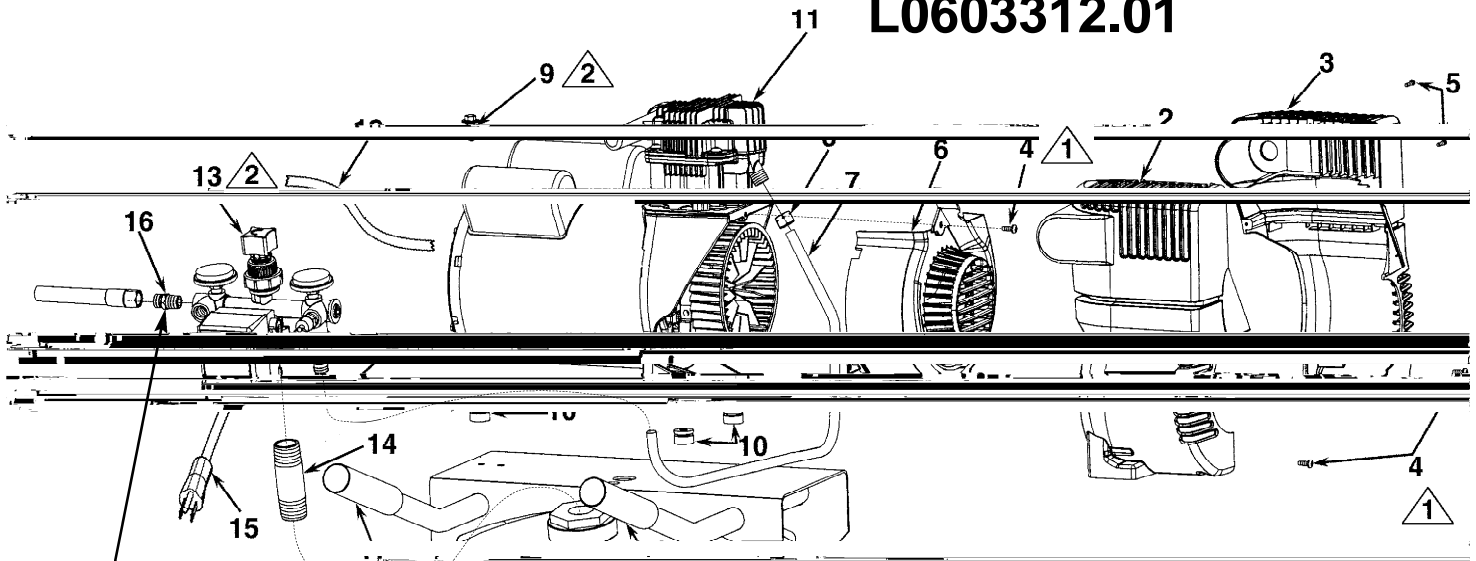

- Attach the hose from the hose reel to this fitting.
- Attachez le tuyau de la bobine de tuyau à cet ajustage de précision.
- Asocie la manguera del carrete de la manguera a esta guarnición.

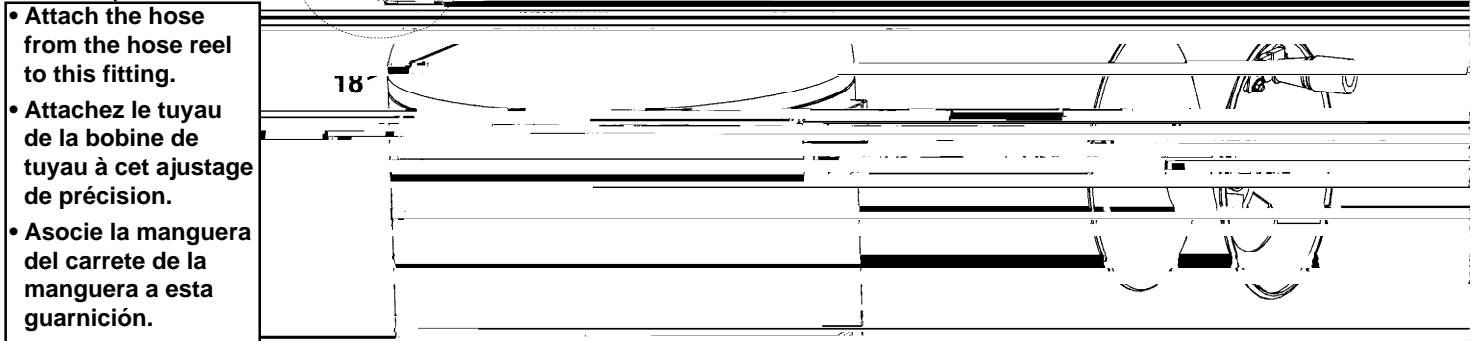

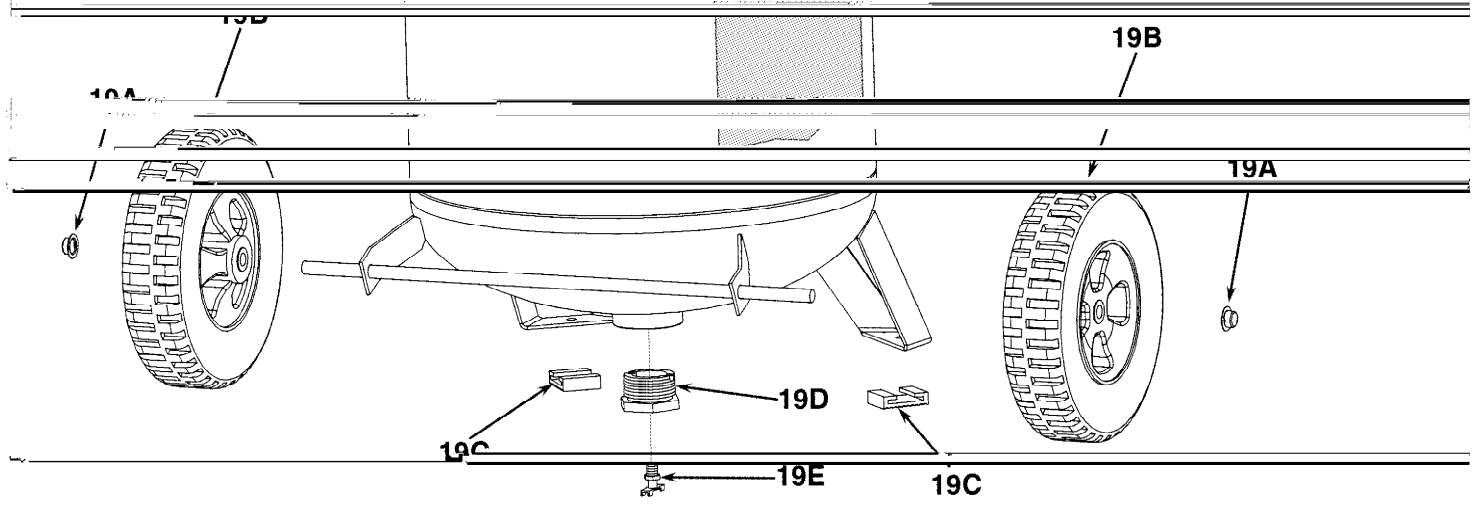

- | | |
|---|---|
| 1 | Torque to 20-30 lbs-in
Serrez de 20 à 30 lbs-in
Torsión hasta 2,3 - 3,4 N.m |
| 2 | Torque to 50-75 lbs-in
Serrez de 50 à 75 lbs-in
Torsión hasta 5,7 - 8,5 N.m |



Note: Tighten compression nut #4 handtight plus 1 full turn.
Note: Serrez l'écrou #4 de compactage solide plus 1 plein tour.
Nota: Apriete la tuerca #4 de la compresión handtight más 1vuelta completa.

PARTS LIST / LISTE DE PIÈCES / LISTA DE LAS PIEZAS

Item Art <u>Art</u>	Part No N° / P <u>Núm / P</u>	Qty Qté <u>Cant</u>	 English <u>Description</u>	 French <u>Description</u>	 Spanish <u>Descripción</u>
1	024-0156	1	Hose reel assy (see insert sheet).....	Assemblage de bobine de tuyau (voir l'insertion couvrir).....	Ensamblaje de carrete de la manguera (vea el separador de millares cubrir)
2	142-0122	1	Shroud, left	Enveloppe	Guardera
3	142-0123	1	Shroud, right	Enveloppe	Guardera
4	N/A	3	Screw, #8-32 x 7/16" lg	Vis	Tornillo
5	N/A	2	Screw, plastite 4-20 x 1"	Vis	Tornillo
6	142-0118	1	Shroud	Enveloppe	Guardera
7	145-0369	1	Transfer tube	Tube	Tubo
8	058-0007	2	Nut, 3/8" O.D. tube.....	Écrou	Tuerca
9	059-0221	3	Bolt, shoulder, 1/4-28.....	Boulon.....	Perno
10	093-0019	3	Grommet.....	Oeillet.....	Arandela de cabo etu
11	040-0326	1	Pump/motor assy See pages 6 & 7	Ensemble pompe/moteur..... Voir les pages 6 et 7	Conjunto de bomba/motor Vea las paginaciones 6 y
12	026-0233	1	Interconnect cord.....	Câble	Cordón
13	See pages 4 & 5	1	Manifold assembly.....	Ensemble du collecteur	Conjunto de múltiple
14	N/A	1	Nipple, 3/4" NPT x 3-1/2"	Manchon fileté	Niple
15	026-0030	1	Power cord.....	Câble	Cordón
16	068-0066	1	Connector, 1/4"NPSM x 1/4" NPT..	Connecteur	Conector
17	093-0031	2	Handle grip	Poignée.....	Empuñadura
18	098-2255	1	Label, warning	D'avertissement étiquette	Amonestadora escritura de la
19	153-0061	1	Tank assembly..... includes 10A-10F.....	Ensemble du réservoir, inclut 10A-10F	Conjunto de tanque, incluye 10A-10F
19A	033-0001	2	Hubcap	Chapeau de moyeu	Tapacubo
19B	095-0031	2	Wheel, 10"	Roue	Rueda
19C	094-0029	2	Pad	Tampon.....	Almohadilla
19D	512-0035	1	Bushing, 1-1/2 NPS x 1/4 NPT..	Bague	Buje
	513-0002	1	O-ring 1-1/2"	Joint torique	Anillo tórico
19E	072-0001	1	Petcock.....	Robinet de décompression..	Llave de desagüe
20	098-2336	1	Label, warning	D'avertissement étiquette	Amonestadora escritura de la

*N/A - These are standard parts available at your local hardware store.

*N/A - Ces pièces sont des pièces standard disponibles en quincaillerie.

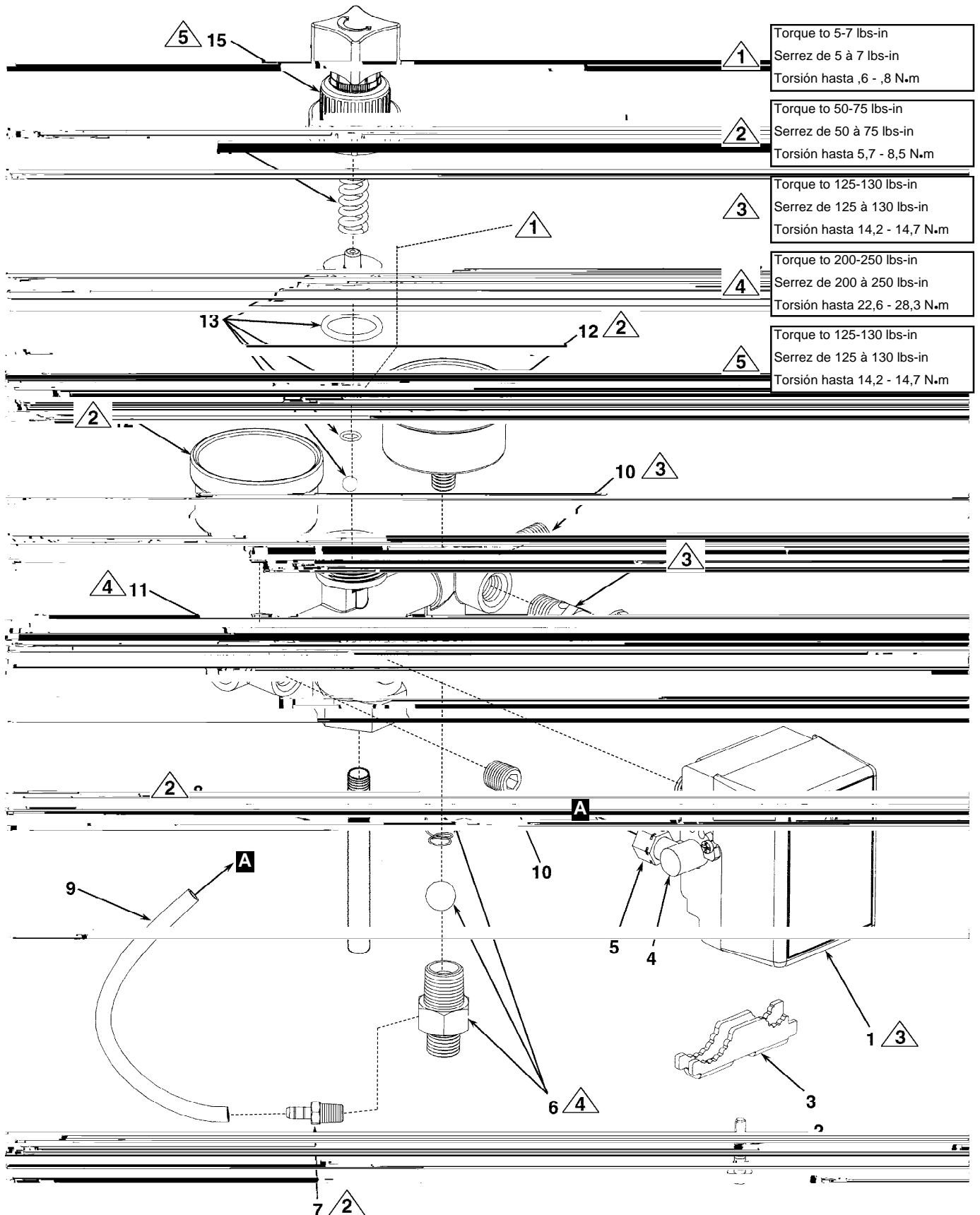

*N/A - Estas son piezas estándares disponibles en su ferretería local.

PARTS DRAWING / DESSIN DES PIÈCES / ESQUEMA DE LA PIEZAS



Note: Tighten compression nut #5 handtight plus 1 full turn.
Note: Serrez l'écrou #5 de compactage sol ide plus 1 plein tour.
Nota: Apriete la tuerca #5 de la compresión handtight más 1 vuelta completa.

PARTS LIST / LISTE DE PIÈCES / LISTA DE LAS PIEZAS

Item Art	Part No N° / P	Qty Qté	 English	 French	 Spanish
<u>Art</u>	<u>Núm / P</u>	<u>Cant</u>	<u>Description</u>	<u>Description</u>	<u>Descripción</u>
1	034-0135	1	Pressure switch <i>includes items 2 - 5</i>	Interrupteur <i>includ les élément 2 - 5</i>	Manómetro <i>incluye los artículo 2 -5</i>
2	061-0121	1	Screw	Vis	Tornillo
3	071-0013	1	Strain Relief	Soulagement de traction	Aliviador de esfuerzo
4	136-0064	1	Bleeder valve <i>includes item 5</i>	Soupape <i>includ les élément 5</i>	Válvula <i>incluye los artículo 5</i>
5	058-0017	1	Nut, 1/4" O.D. tube	Écrou	Tuerca
6	139-0013	1	Check valve assy	Clapet de retenue	Válvula de contraflujo
7	068-0061	1	Connector, 1/16 NPT x 1/4"	Connecteur	Conector
8	065-0089	1	Nipple, 1/8" x 4"	Manchon fileté	Niple
9	145-0325	1	Bleeder tube <i>Also purchase 058-0017 qty 1 también être acheté</i>	Tube..... <i>aussi debe comprar</i>	Tubo
10	062-0035	2	Plug	Bouchon	Tapón
11	041-0045	1	Manifold.....	Collecteur.....	Múltiple
12	032-0065	2	Gauge	Manomètre.....	Manómetro
13	105-0004	1	Regulator repair kit	Jeu de pièces de réparation	Juego de reparación
14	055-0005	1	Spring	Ressort.....	Resorte
15	137-0001	1	Knob assy	Ensemble du bouton	Conjunto de perilla
16	136-0056	1	Valve, ASME	Soupape.....	Válvula

PARTS DRAWING / DESSIN DES PIÈCES / ESQUEMA DE LA PIEZAS

- 1** Torque to 88-96 lbs-in
Serrez de 88 à 96 lbs-in
Torsión hasta 9,9 - 10,8 N•m
- 2** Torque to 11-14 lbs-in
Serrez de 11 à 14 lbs-in
Torsión hasta 1,2 - 1,6 N•m
- 3** Torque to 50-65 lbs-in
Serrez de 50 à 65 lbs-in
Torsión hasta 5,6 - 7,3 N•m
- 4** Torque to 75-88 lbs-in
Serrez de 75 à 88 lbs-in
Torsión hasta 8,5 - 9,9 N•m

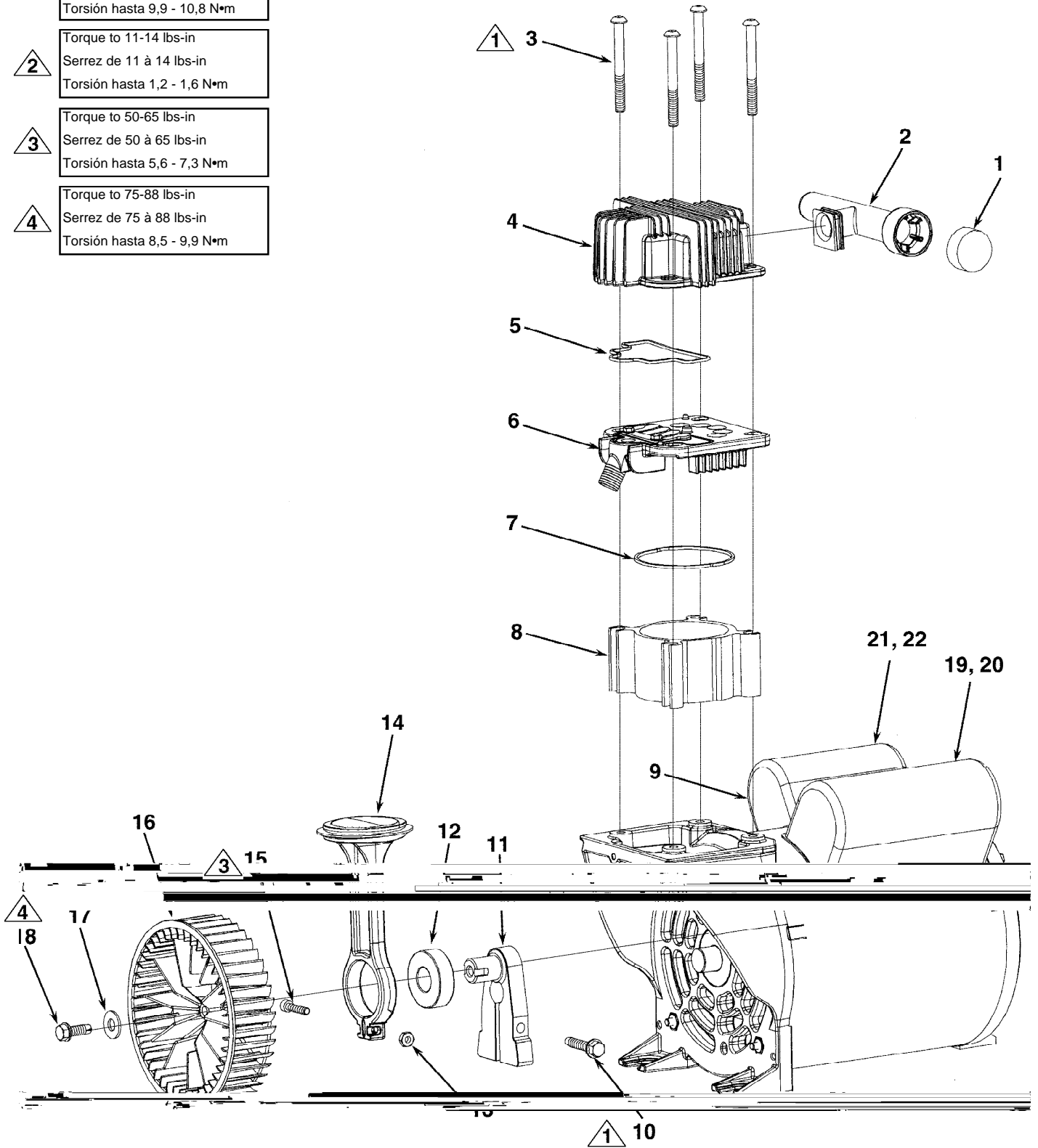

MODEL L0603312.01

PARTS LIST / LISTE DE PIÈCES / LISTA DE LAS PIEZAS

Item Art <u>Art</u>	Part No N° / P <u>Núm / P</u>	Qty Qté <u>Cant</u>	<u>Description</u>	<u>Description</u>	<u>Descripción</u>
1	019-0186	1	Filter.....	Filtre.....	Filtro
2	019-0192	1	Filter/intake muffler.....	Silencieux de Filter/intake....	Silenciador de Filter/intake
3	061-0136	4	Screw 1/4-20 x 2-1/2".....	Vis.....	Tornillo
4	042-0104	1	Head, casting.....	Tête, moulant.....	Pista, echando
5	054-0226	1	O-ring.....	Joint torique.....	Anillo tórico
6	043-0171	1	Valve plate assy..... (includes items 5 & 7).....	Ensemble de la plaque de ... Soupape (inclut les éléments 5 et 7).....	Conjunto de placa de válvula (incluye los artículos 5 y 7)
7	054-0225	1	O-ring, .070 sq.....	Joint torique.....	Anillo tórico
8	050-0052	1	Cylinder.....	Cylindre.....	Cilindro
9	040-0326	1	Pump/motor assy (6 peak hp).....	Ensemble pompe/moteur.....	Conjunto de bomba/motor
10	061-0135	1	Screw, 1/4-20 x 1-1/2" hex.....	Vis.....	Tornillo
11	053-0084	1	Crankshaft, eccentric.....	Vilebrequin, excentrique.....	Cigüeñal, excéntrico
12	051-0086	1	Bearing, ball.....	Roulement.....	Cojinete
13	N/A	1	Nut, #10-32 square.....	Écrou.....	Tuerca
14	048-0105	1	Piston assy..... (includes items 8, 13 & 15).....	Ensemble du piston..... (inclut les éléments 8, 13 et 15).....	Conjunto de pistón (incluye los artículos 8, 13 y 15)
15	N/A	1	Screw, #10-32 x 7/8".....	Vis.....	Tornillo
16	027-0033	1	Fan, plastic.....	En plastique ventilateur.....	Plástico ventilador
17	060-0144	1	Washer, 1/4".....	Rondelle.....	Arandela
18	061-0134	1	Screw, 1/4-20 x 3/4".....	Vis.....	Tornillo
19	166-0112	1	Start capacitor, 6 peak hp.....	Condensateur.....	Condensador
20	166-0114	1	Start capacitor cover,..... 6 peak hp	Couvercle.....	Tapa
21	166-0113	1	Run capacitor, 6 peak hp.....	Condensateur.....	Condensador
22	166-0115	1	Run capacitor cover..... 6 peak hp	Couvercle.....	Tapa

*N/A - These are standard parts available at your local hardware store.

*N/A - Ces pièces sont des pièces standard disponibles en quincaillerie.

*N/A - Estas son piezas estándares disponibles en su ferretería local.