

1695576

# Parts Manual

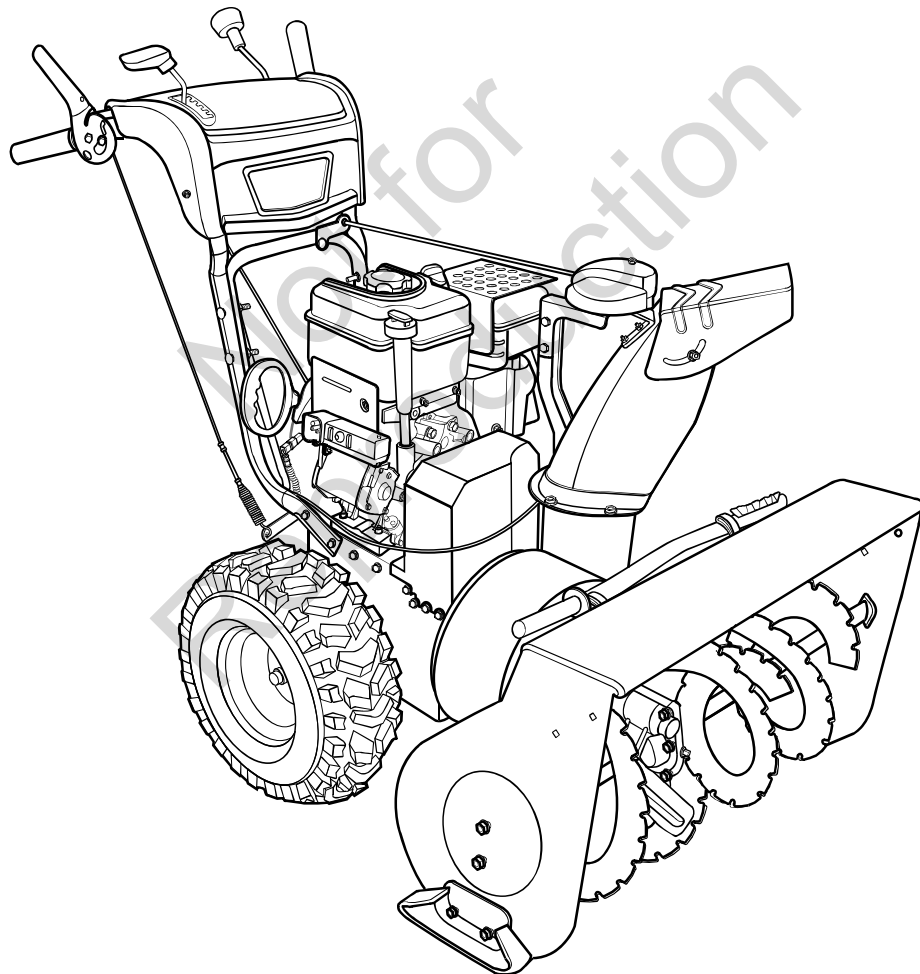

Manual Part No. 1737374

Revision B

Rev. Date 1/2009

TP 400-5000-B-ST-J

Not for  
Reproduction

<b>PRODUCT COMPONENTS</b>	<b>PAGES</b>
Engine and Frame Group - Steerable .....	4
Traction Drive Group .....	6
Auger Housing .....	8
Discharge Chute .....	10
Handle & Cover Panel Assembly .....	12
Wheel and Tire Group .....	16
Decals .....	18
Gear Case .....	20
<b>Torque Specification Chart .....</b>	<b>Inside Back Cover</b>

Not for  
Reproduction

# Engine and Frame Group - Steerable

**NOTE:** Unless noted otherwise, use the standard hardware torque specification chart.

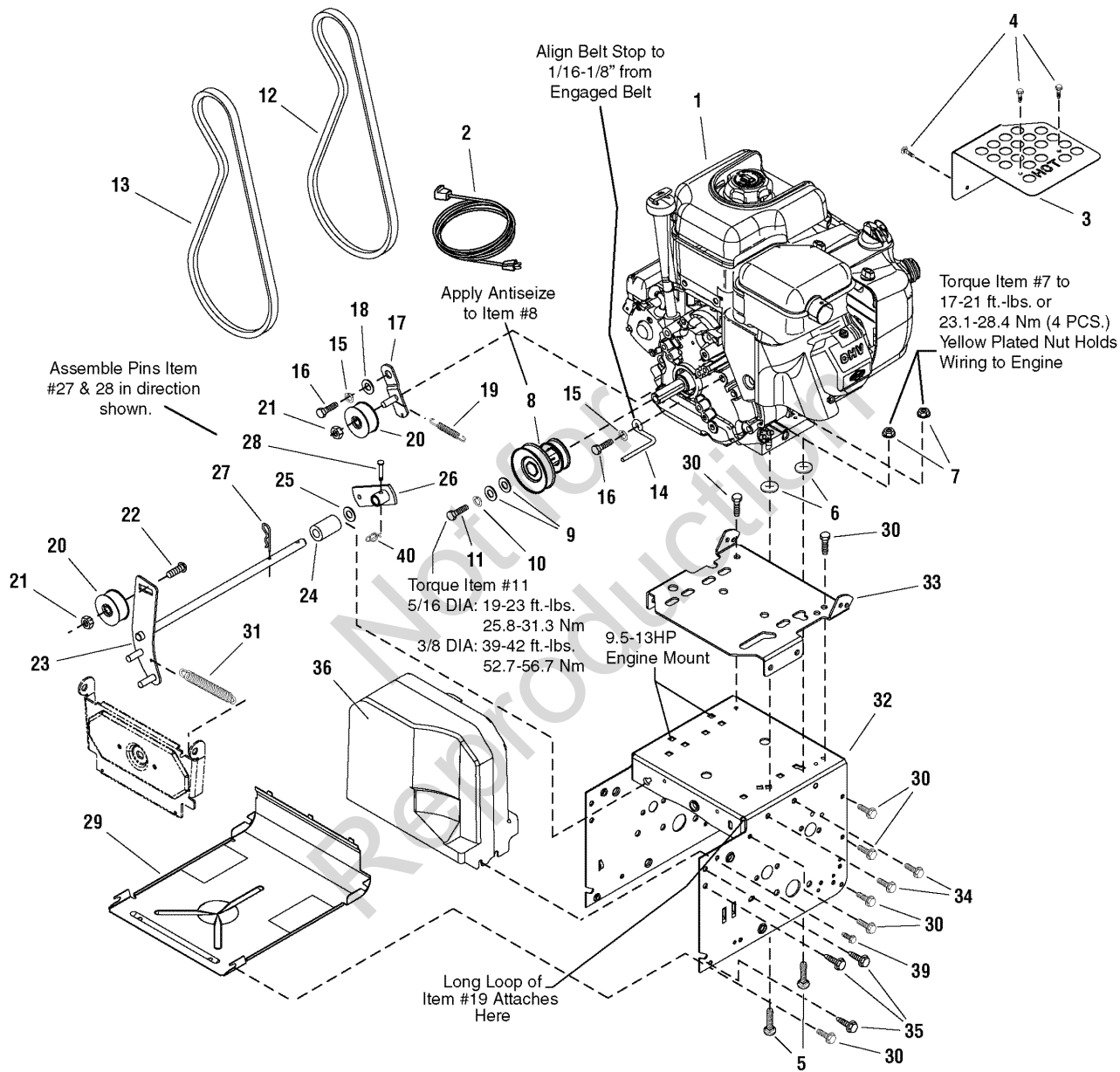

**The above parts group applies to the following Mfg. Nos.:**

1695576 - Brute 13.5 TP Snowthrower (2008)

## Engine and Frame Group - Steerable

REF NO	PART NO.	QTY.	DESCRIPTION
1	----	1	ENGINE, B&S Powerbuilt * (Model # 20M1140136E1)
2	1724064SM	1	CORD, Electric Start
3	1734698SM	1	GUARD, Muffler
4	1736103SM	3	SCREW, Hex Washer Head Taptite, 10-24 x 3/8
5	002X97MA	4	CARRIAGE BOLT
6	028X76MA	4	NUT, Speed
7	2831277SM	4	NUT, Hex Flange, 5/16-18 Whiz Lock Small
8	1501109MA	1	PULLEY, Engine
9	1922755SM	2	WASHER, 5/16
10	1916965SM	1	LOCKWASHER, 3/8
11	1960428SM	1	CAPSCREW, Hex Head, 5/16-24 x 1-1/4 G8
12	1733324SM	1	V-BELT, Drive
13	1736421YP	1	V-BELT, Auger
14	1733014SM	1	STOP, Belt
15	1917356SM	2	LOCKWASHER, Spring 5/16
16	1921515SM	2	CAPSCREW, Hex Head, 5/16-24 x 3/4 G5
17	1501112YZMA	1	IDLER BRACKET ASSEMBLY, Drive Belt
18	1501065MA	1	BUSHING, Idler Bracket
19	53704MA	1	SPRING, Extension Idler
20	1502120MA	2	IDLER, Plastic Ball Bearing
21	1960251SM	2	NUT, Hex Jam, 3/8-16
22	585781MA	1	CARRIAGE BOLT, 3/8-16 x 1-1/4
23	1501226YZMA	1	IDLER ASSEMBLY, Auger
24	1501200MA	1	SPACER, Auger Idler
25	1960027SM	1	WASHER, 1/2
26	1733451SM	1	BRACKET & HUB ASSEMBLY, Spring
27	711682MA	1	PIN, Hair
28	1736381YP	1	PIN, Clevis
29	1740906ASM	1	PANEL, Bottom
30	1927429SM	12	SCREW, Hex Washer Head Taptite, 1/4-20 x 5/8
31	165X159MA	1	SPRING, Extension Auger Idler
32	1740571ZMA	1	FRAME BOX
33	1733583ZYP	1	PLATE, Engine Mount
34	1924856SM	6	SCREW, Hex Washer Head Taptite, 5/16-18 x 1/2
35	1664847SM	4	SCREW, Hex Washer Head Taptite, 5/16-18 x 3/4
36	1502169MA	1	COVER, Belt
39	26X306MA	2	SCREW, Hex
40	7023590SM	1	PIN, Cotter, Self Lock, .25

### Footnotes

Note\* See your local Briggs & Stratton distributor for parts and service.

---

### The above parts group applies to the following Mfg. Nos.:

1695576 - Brute 13.5 TP Snowthrower (2008)

## Traction Drive Group

NOTE: Unless noted otherwise,  
use the standard hardware torque  
specification chart.

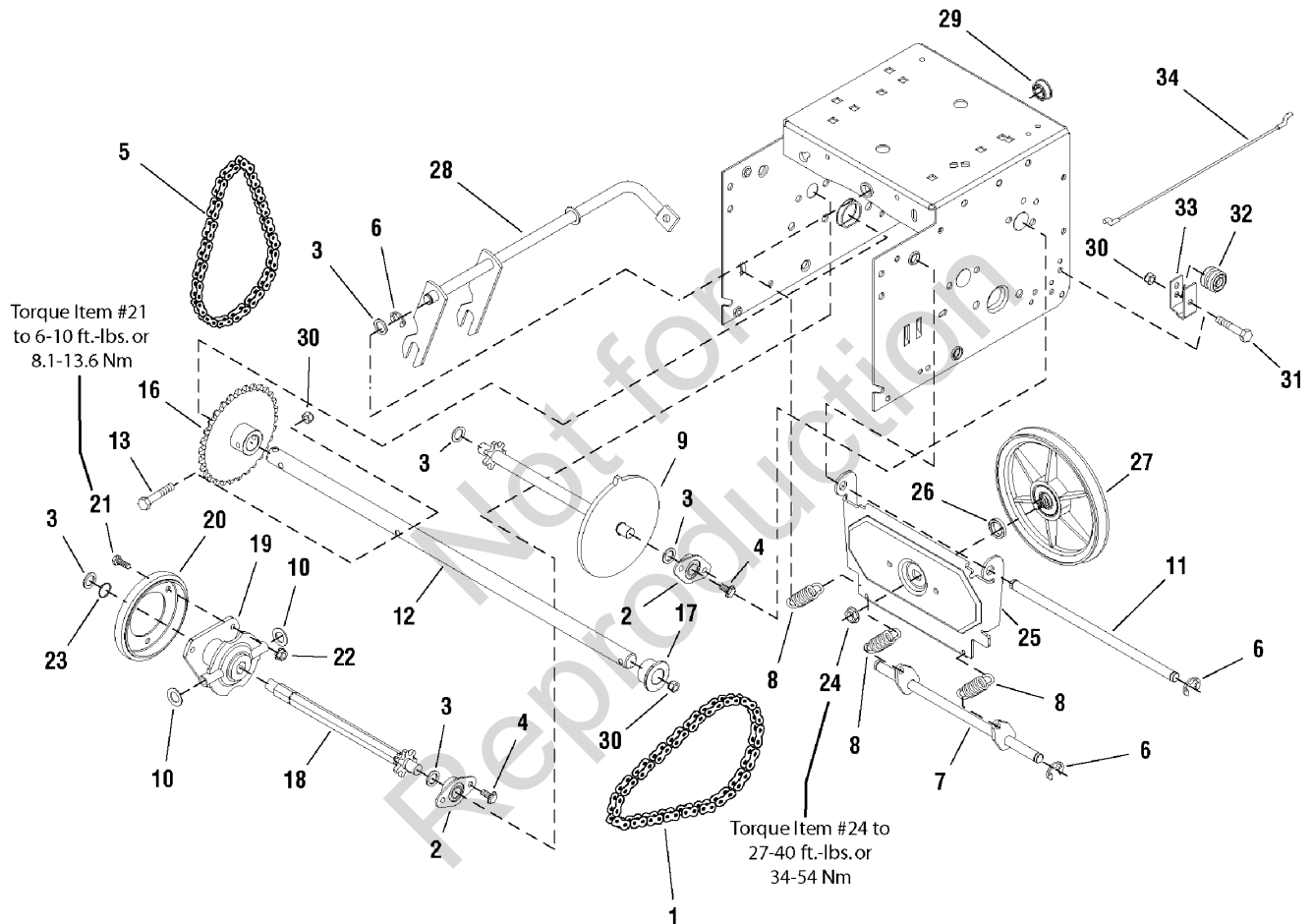

The above parts group applies to the following Mfg. Nos.:  
1695576 - Brute 13.5 TP Snowthrower (2008)

## Traction Drive Group

REF NO	PART NO.	QTY.	DESCRIPTION
1	579851MA	1	CHAIN, Roller
2	334163MA	4	RETAINER & BUSHING ASSEMBLY
3	579858MA	5	WASHER
4	1924856SM	8	SCREW, Hex Washer Head Taptite, 5/16-18 x 1/2
5	579868MA	1	CHAIN, Roller
6	11X30MA	5	RETAINER, Ring 7/16
7	1502105YZMA	1	SPRING LINK ASSEMBLY
8	1736469YP	3	SPRING, Extension
9	1501090MA	1	SPROCKET, Set
10	1960027SM	2	WASHER, 1/2
11	1501092YZMA	1	AXLE, Swing Plate
12	1501563MA	1	AXLE, Bushing
13	01X193MA	1	BOLT, Hex 1/4-20 x 1-3/4 G8
16	1501089MA	1	SPROCKET, Axle
17	1501114MA	2	BEARING, Axle D-Hole
18	1501100MA	1	HEX SHAFT & SPROCKET ASSEMBLY
19	337029MA	1	HUB, Friction Wheel & Bearing
20	1501435MA	1	WHEEL, Friction
21	1921959SM	3	CAPSCREW, Hex Head 1/4-20 x 5/8 G5
22	1928372SM	3	NUT, Hex KEPS 1/4-20
23	1733326SM	1	RING, Retaining Extension
24	15X114MA	1	NUT, 3/8-24 Flange Lock
25	1501057YZMA	1	PLATE, Swinging
26	1501158MA	1	SPACER, Friction Pulley
27	1501115MA	1	FRICTION PULLEY ASSEMBLY
28	1501110YZMA	1	SPEED SELECT ASSEMBLY
29	579944MA	1	BEARING, Flange
30	1920397SM	2	NUT, Hex Lock ESNA Light 1/4-20
31	1922837SM	1	CAPSCREW, Hex Head, 1/4-20 x 1-1/2 G5
32	579860MA	1	SPOOL CABLE, Auger Control
33	1501059YZMA	1	BRACKET, Cable Spool
34	1501122MA	1	CABLE, Front Drive Lower All

### Footnotes

The above parts group applies to the following Mfg. Nos.:

1695576 - Brute 13.5 TP Snowthrower (2008)

# Auger Housing

**NOTE:** Unless noted otherwise, use the standard hardware torque specification chart.

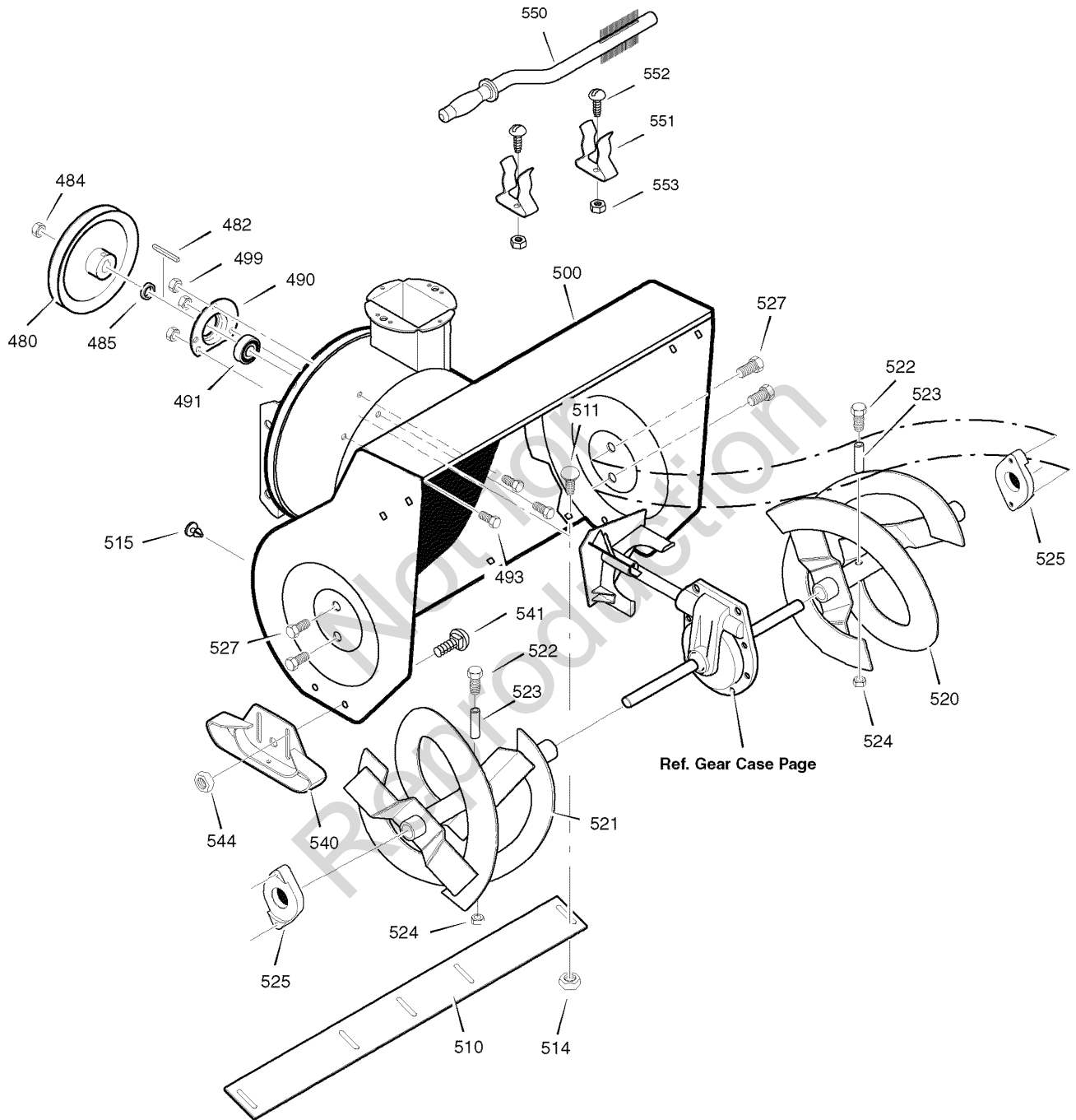

**The above parts group applies to the following Mfg. Nos.:**  
1695576 - Brute 13.5 TP Snowthrower (2008)

## Auger Housing

REF NO	PART NO.	QTY.	DESCRIPTION
480	583146MA	1	PULLEY, 4L 8.40 OD
482	2001022MA	1	KEY, SQUARE 3/16 X 3/4
484	15X112MA	1	NUT, 1/2-20
485	1501158MA	1	SPACER, FRICTION PULLEY
490	582957YZMA	1	RETAINER, BALL BEARING
491	1705897SM	1	BEARING, BALL
493	001X45MA	3	BOLT, HEX 5/16-18 X 0.62
499	710026MA	3	NUT, 5/16-18 HEXWDFLLK
500	1736490ZYP	1	HOUSING, ASSEMBLY
510	1740746HMA	1	BLADE, SCRAPER
511	340720MA	4	BOLT, 5/16-18 X 0.75
514	710026MA	4	NUT, 5/16-18
515	760040MA	4	PLUG PANEL, BLACK
520	1740740HMA	1	AUGER, ASSEMBLY, LH
521	1740741HMA	1	AUGER, ASSEMBLY, RH
522	9524MA	2	SCREW, 1/4-20 X 1.75
523	3943MA	2	SPACER, SLEEVE
524	73826MA	2	NUT, 1/4-20
525	53757MA	2	BEARING, FLANGE
527	25X021MA	4	SCREW, 5/16-18 x 0.75
540	1740913AYP	2	SKID, HEIGHT ADJUST
541	340720MA	4	BOLT, 5/16-18 X 0.5
544	710026MA	4	NUT, 5/16-18
550	1501576MA	1	BRUSH, CLEANOUT
551	1736620YP	2	CLIP, RETAINER
552	1960569SM	2	SCREW
553	15X146MA	2	NUT
--	1501216MA	--	KIT, SHEAR BOLT

## Footnotes

The above parts group applies to the following Mfg. Nos.:

1695576 - Brute 13.5 TP Snowthrower (2008)

# Discharge Chute

NOTE: Unless noted otherwise, use the standard hardware torque specification chart.

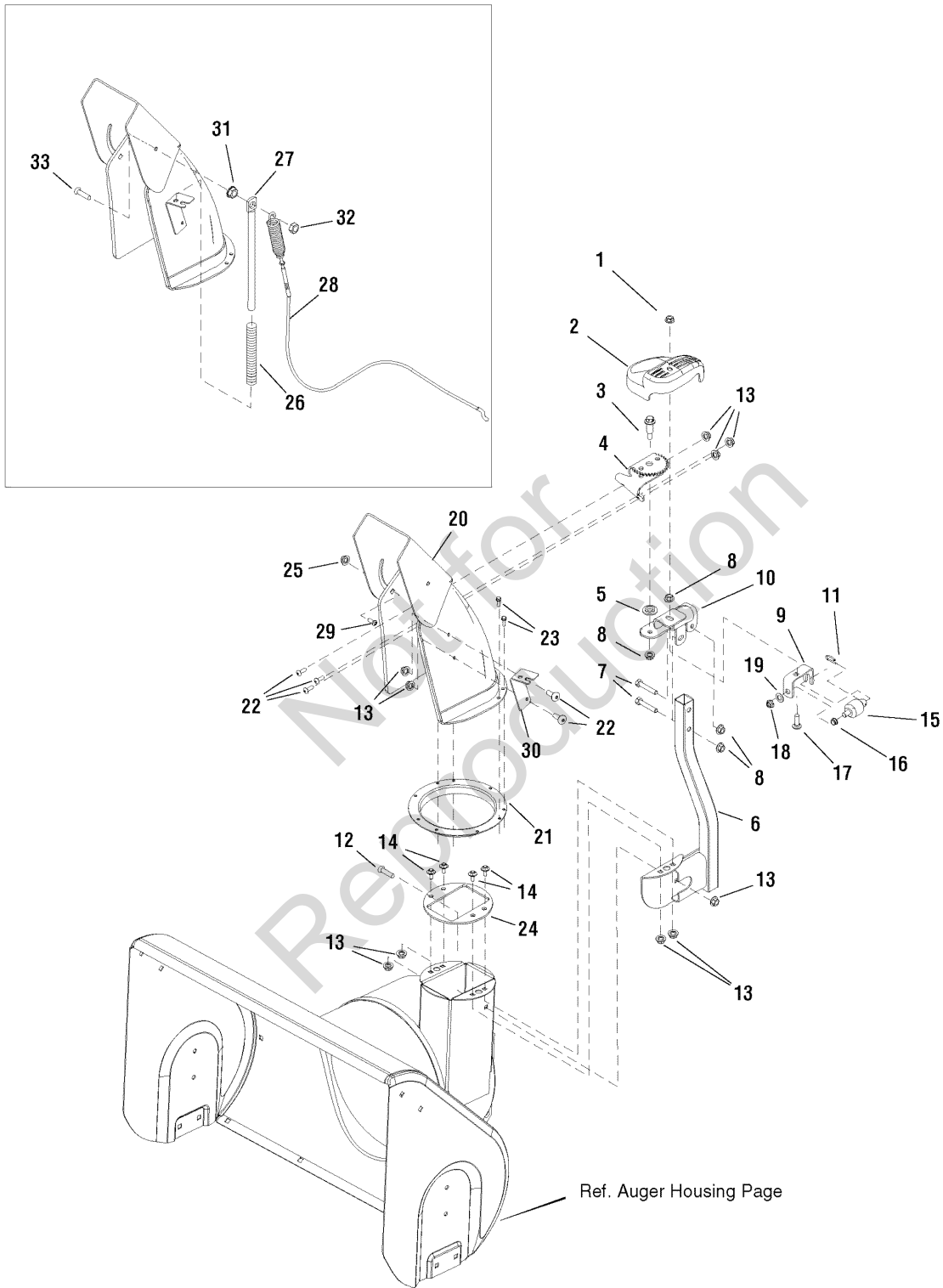

The above parts group applies to the following Mfg. Nos.:

1695576 - Brute 13.5 TP Snowthrower (2008)

## Discharge Chute

REF NO	PART NO.	QTY.	DESCRIPTION
1	1935048SM	1	NUT, Hex Flange 5/16-18 Two Way Lock
2	1734442SM	1	COVER, Gears
3	1732412SM	1	BOLT, Shoulder 5/16-18 G5
4	1736038YP	1	GEAR & SUPPORT ASSEMBLY, Chute
5	1733026SM	1	WASHER, Powdered Metal
6	1736195AYP	1	CHUTE SUPPORT ASSEMBLY
7	1922127SM	2	CAPSCREW, Hex Head 5/16-18 x 1-3/4 G5
8	1960684SM	4	NUT, Hex KEPS 5/16-18 Conical Washer
9	1734440SM	1	SUPPORT, Worm "U" 10GA
10	1734423ASM	1	SUPPORT, Gear & Chute 10GA
11	1501293MA	1	PIN, Hair Chute Gear
12	02X101MA	1	BOLT, CARRIAGE 0.25-20 x 0.75
13	5025391SM	10	NUT, 1/4-20 HEX NYLOCK FLANGE
14	691005	4	SCREW, HEX WASHER
15	1734439SM	1	WORM, Chute L.H.
16	1667588SM	1	BUSHING
17	1931335SM	1	CARRIAGE BOLT, 5/16-18 x 1 G5
18	1960762SM	1	NUT, Hex Lock Jam ESNA Lite 3/8-24
19	1734542SM	1	WASHER, Cup
20	1736719YP	1	DISCHARGE CHUTE ASSEMBLY
21	1736444AYP	1	CHUTE RING
22	1960715SM	5	SCREW, Truss Head, 1/4-20 x 3/4
23	1925003SM	4	CAPSCREW, Hex Head Taptite, 1/4-20 x 1/2
24	1735767YP	1	GUIDE, CHUTE RING
25	1960686SM	1	NUT-HEX FLANGE.312-18 ESNA
26	1734647SM	1	SPRING, Compression
27	1734708ASM	1	ROD, Spring
28	1732971SM	1	CABLE DEFLECTOR
29	1960086SM	1	SCREW, Torx Truss Head, 5/16-18 x 7/8, Black
30	1736378AYP	1	BRACKET, CABLE DEFLECTOR
31	1960636SM	1	NUT, Hex KEPS, 5/16-18
32	1928698SM	1	JAM NUT, Top Lock, 5/16-18
33	1960767YP	1	SCREW, BUTTON HEAD, 5/8-18 x 1.25

## Footnotes

The above parts group applies to the following Mfg. Nos.:

1695576 - Brute 13.5 TP Snowthrower (2008)

# Handle & Cover Panel Assembly

NOTE: Unless noted otherwise,  
use the standard hardware torque  
specification chart.

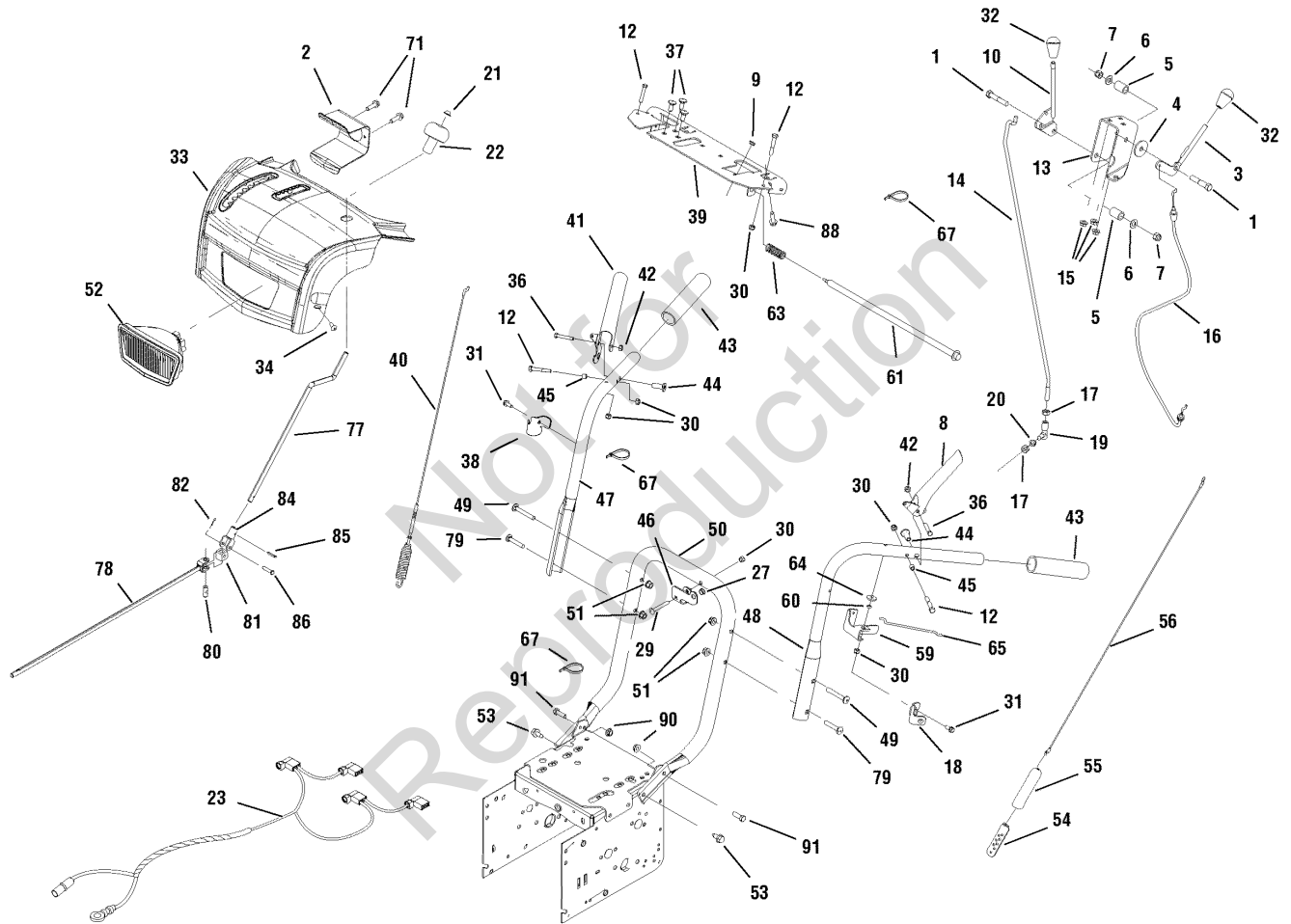

The above parts group applies to the following Mfg. Nos.:

1695576 - Brute 13.5 TP Snowthrower (2008)

## Handle & Cover Panel Assembly

REF NO	PART NO.	QTY.	DESCRIPTION
1	1923701SM	2	CAPSCREW-HEX. 375 - 16x2.00
2	1736305AYP	1	BRACKET, LIGHT MOUNT
3	1736192YP	1	LEVER-DEFLECTOR CONTROL
4	1924356SM	1	WASHER, 3/8
5	50786MA	2	SPRING- COMPRESSION .509 x .75 2
6	1918266SM	2	WASHER- O. 375 O. 4 1 x 0.8 1 x .06
7	1919439SM	2	NUT -HEXLK ESNA LT . 38- 16NC3B
8	1736324YP	1	LEVER-CLUTCH LH PLASTISOL DIP
9	1667588SM	1	BUSHING
10	1733614SM	1	ROD & BRACKET ASSEMBLY, SPEED
12	1921962SM	4	CAPSCREW-HEX .250- 20 x 1 . 75
13	1733045ASM	1	BRKT- SPEED & DEFLECTOR CONTROL
14	1734354SM	1	ROD-LINK SPEED CONTROL
15	1931277SM	3	NUT-HEX FLANGE . 3 12- 18 WHIZ
16	1732971SM	1	CABLE ASSEMBLY-DEFLECTOR
17	2820263SM	2	NUT-HEX . 3 12- 24 YELLOW
18	1736147YP	1	MNTG BRKT - DASH LH
19	50782MA	1	BALLJOINT-STEEL
20	1917356SM	1	LOCKWASHER - SPRING . 312 BLK
21	1960093SM	1	NUT, PUSH PAL STUD CAPPED 3/8
22	1714084SM	1	KNOB, SPINNER
23	1737019YP	1	WIRING HARNESS
27	1501874MA	1	BUSHING
29	1931323SM	1	CARRIAGE BOLT, 1/4-20 x 2
30	1920397SM	6	NUT-HEX LOCK ESNA .250-20
31	1927429SM	2	SCREW-HEX WSHR HD TT .25- 20x. 62
32	1732470SM	2	KNOB
33	1736345YP	1	COVER-PANEL ASS'Y
34	1960556SM	2	SCREW-PAN HD TR x . 250-20 x .75 TAP
36	1922837SM	2	CAPSCREW- HEX .2 50 -20 x 1 .50
37	1931333SM	3	CARRIAGE BOLT . 31 2- 18 x . 75
38	1736354YP	1	MNTG BRKT - DASH RH
39	1735628AYP	1	SUPPORT-DASH PANEL
40	1732471SM	1	CABLE & SPRING ASSEMBLY
41	1736323YP	1	GRIP-CLUTCH-RH PLASTISOL
42	1923358SM	2	NUT-HEX CTR LOCK. 250- 20 BLK
43	1726317SM	2	FOAM GRIP
44	1736542YP	2	SPACER- HANDLE-YELLOW
45	1678392SM	2	SPACER- 0.265x0.370x.330
46	1735589YP	1	BRACKET, ROD SUPPORT
47	1734587ASM	1	HANDLE-UPPER RH
48	1734586ASM	1	HANDLE-UPPER LH

### Footnotes

The above parts group applies to the following Mfg. Nos.:

1695576 - Brute 13.5 TP Snowthrower (2008)

# Handle & Cover Panel Assembly

NOTE: Unless noted otherwise,  
use the standard hardware torque  
specification chart.

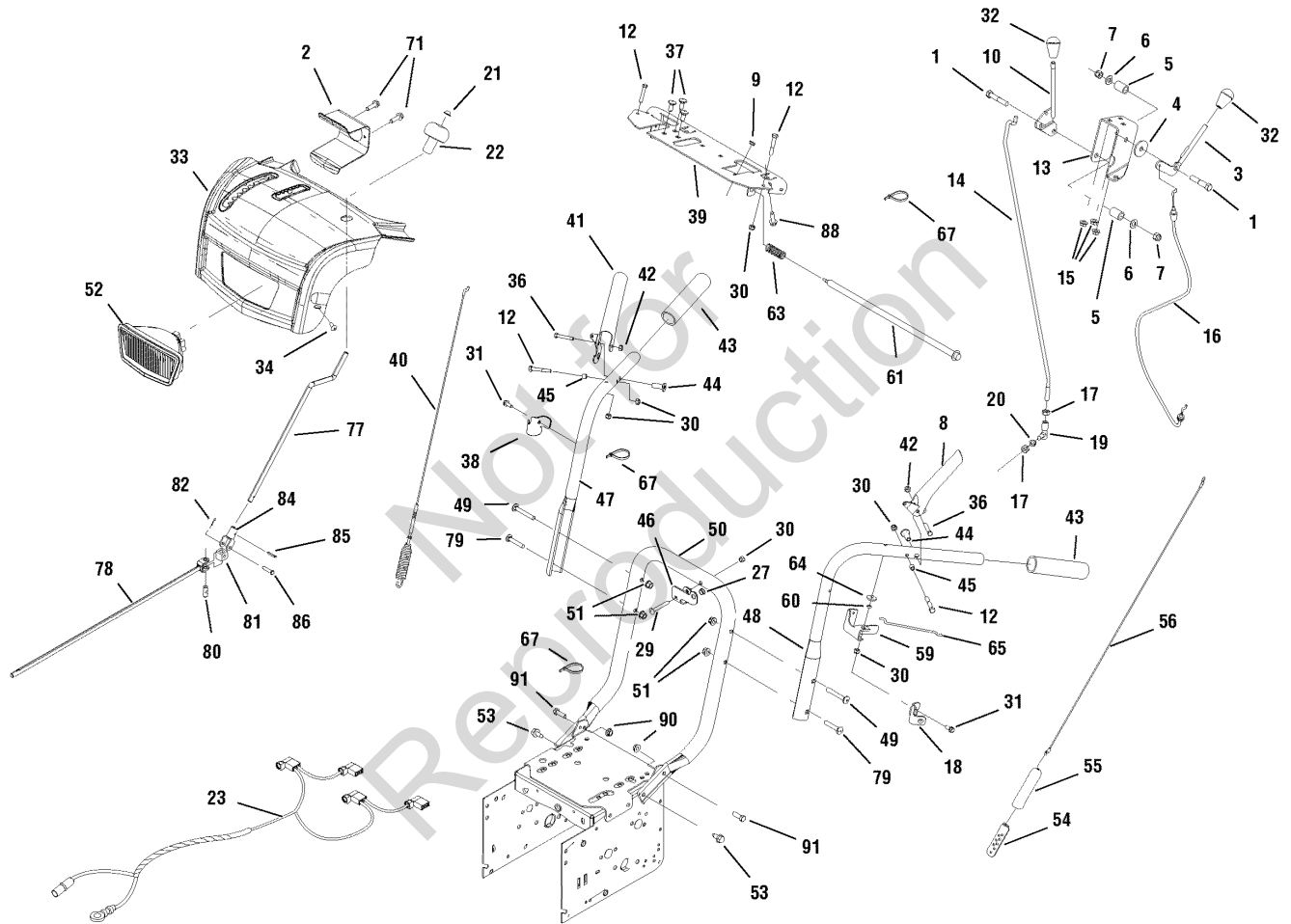

The above parts group applies to the following Mfg. Nos.:

1695576 - Brute 13.5 TP Snowthrower (2008)

## Handle & Cover Panel Assembly

REF NO	PART NO.	QTY.	DESCRIPTION
--	-----	1	BULB, TWIN LIGHT (15W 12V)
50	1736301AYP	1	HANDLE-LOWER
49	1960723SM	2	BOLT-RD HD SO NK .312-18x2.25
51	1960686SM	4	NUT-HEX FLANGE.312-18 ESNA
52	1736208YP	1	HEAD LIGHT ASSEMBLY
53	1664847SM	2	SCREW-HEX WSHR HD TT .31-18x.75
54	313441MA	1	BRACKET-CABLE ADJ
55	308146MA	1	BOOT-CONTROL SPRING
56	1502113MA	1	CABLE-DRIVE
59	1733505ASM	1	BRACKET-FREE HAND CONTROL
60	1733095SM	1	SPACER-PWDR METAL YELLOW
61	1736363YP	1	ROD-FREE HAND CONTROL
63	2108360SM	1	SPRING-COMP.53x2.25 .059 WIRE
64	1960353SM	1	WASHER-.250.26x0.84x.12
65	1736360YP	1	ROD-HOLDDOWN
67	1701011SM	5	TIE-SELF LOCKING .184WDx7.31
71	316042MA	2	SCREW, 10 X .62
77	1735661YP	1	CRANK ROD
78	1735660YP	1	CHUTE, CRANK
79	1931338SM	2	BOLT-RD HD SH SO NK .312-18x1.75
80	578060MA	1	PIN, UNIVERSAL JOIINT
81	578063MA	1	HOUSING, UNIVERSAL
82	579493MA	1	PIN, COTTER
84	1733611SM	1	YOKE ADAPTER ASSEMBLY
85	1501293MA	2	PIN, HAIR
86	578309MA	2	PIN, CLEVIS
88	7091081SM	2	SCREW HEX HD, .25-15x. 75
90	1935048SM	2	NUT-HEX FLANGE .31-18 2-WAY LK
91	1921333SM	1	CAP SCREW-HEX .312-18x1.00

### Footnotes

The above parts group applies to the following Mfg. Nos.:

1695576 - Brute 13.5 TP Snowthrower (2008)

## Wheel and Tire Group

NOTE: Unless noted otherwise,  
use the standard hardware torque  
specification chart.

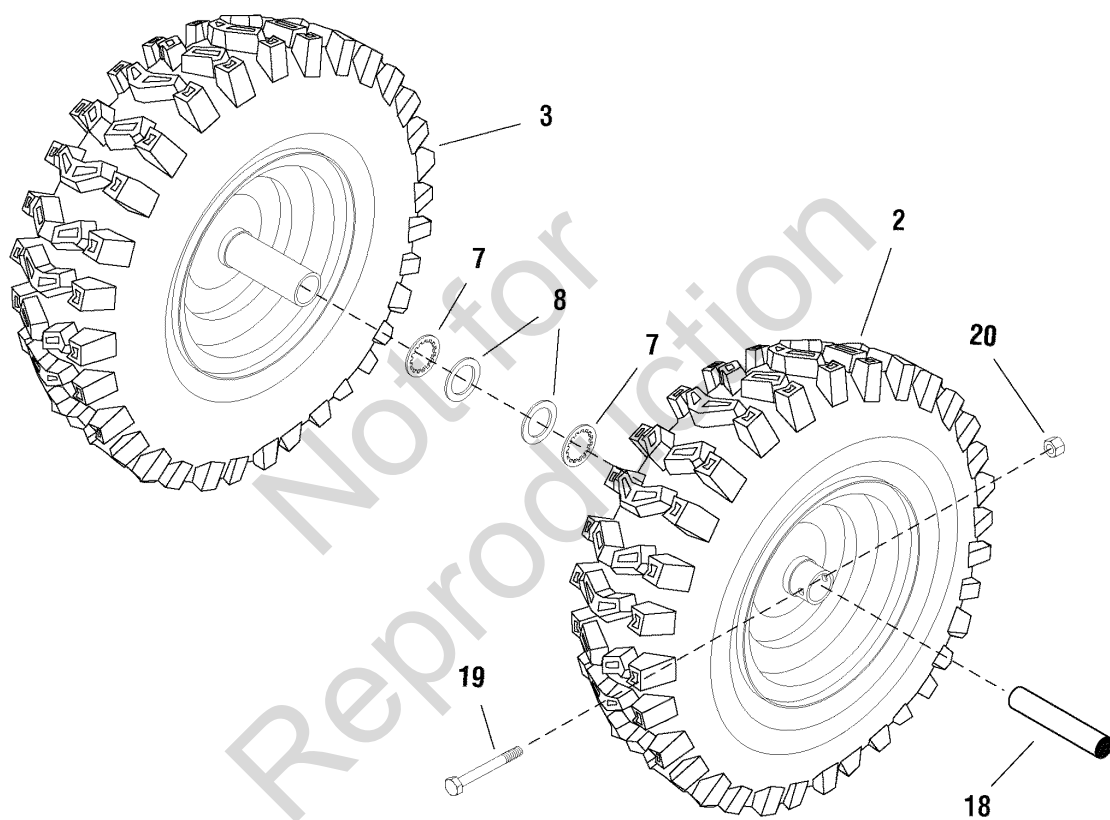

The above parts group applies to the following Mfg. Nos.:

1695576 - Brute 13.5 TP Snowthrower (2008)

## Wheel and Tire Group

REF NO	PART NO.	QTY.	DESCRIPTION
2	1736622YP	1	WHEEL & TIRE ASSEMBLY, L.H. SNOW XTRAC 16 x 4.8-8
3	1736621YP	1	WHEEL & TIRE ASSEMBLY, R.H. SNOW XTRAC 16 x 4.8-8
7	1657528SM	2	RETAINER, Ring
8	712120MA	2	WASHER, Flat .765 x 1.12 x .06 YZ
18	1501138MA	2	BUSHING, WHEEL
19	577015MA	2	SCREW, 1/4-20 X 1.75 HH
20	15X145MA	2	NUT, 1/4-20 HEX NYLOCK

Not for  
Reproduction

### Footnotes

---

**The above parts group applies to the following Mfg. Nos.:**

1695576 - Brute 13.5 TP Snowthrower (2008)

## Decals

NOTE: Unless noted otherwise,  
use the standard hardware torque  
specification chart.

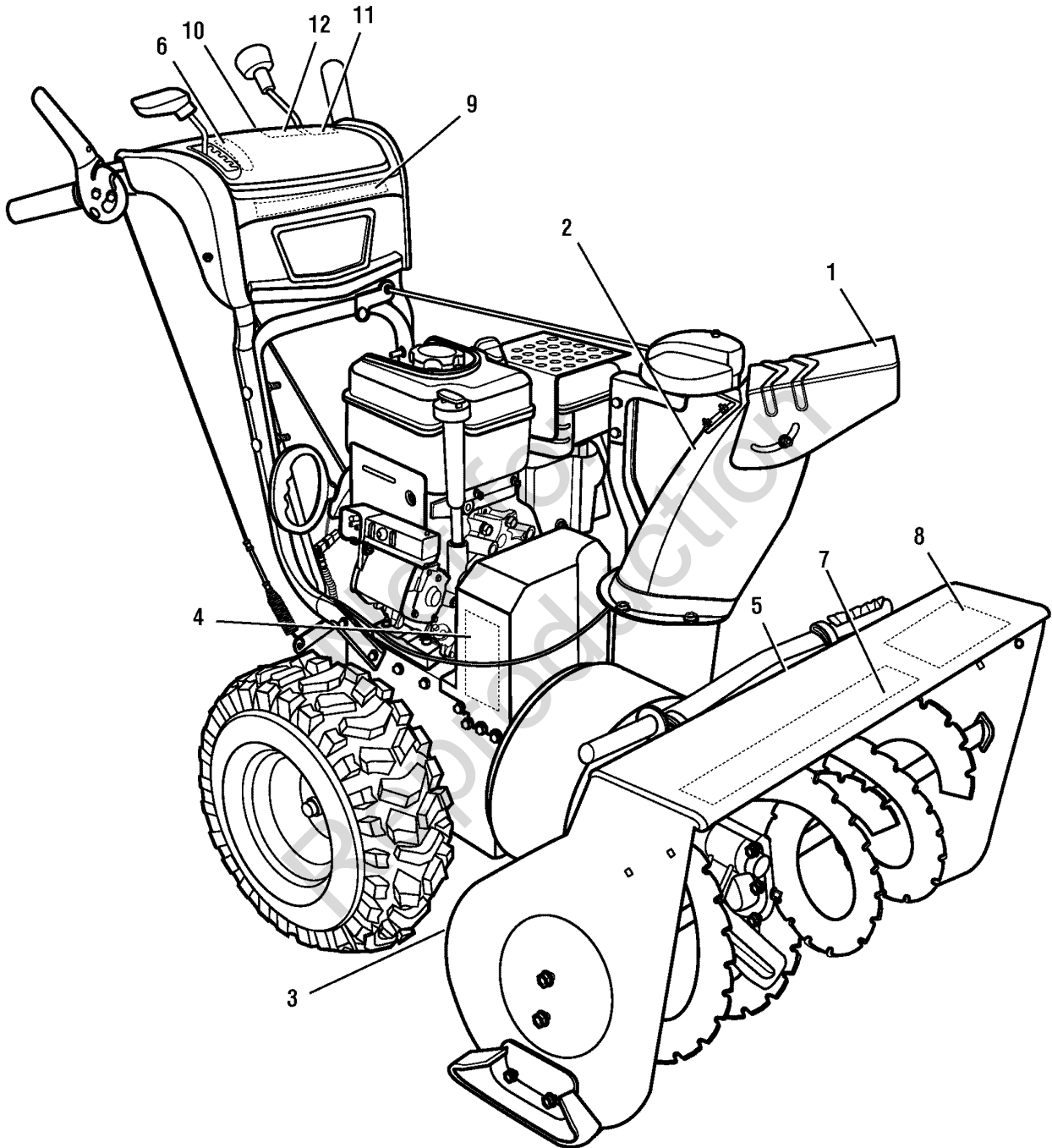

The above parts group applies to the following Mfg. Nos.:

1695576 - Brute 13.5 TP Snowthrower (2008)

## Decals

REF NO	PART NO.	QTY.	DESCRIPTION
1	1736328YP	1	DECAL, THOWN OBJECTS
2	1736897YP	1	DECAL, DANGER CHUTE
3	1740980MA	1	DECAL, ISO AUGER FR/EN
4	5131MA	1	DECAL, BELT STRETCH
5	48X5960MA	1	DECAL, THROWN OBJECTS
6	1736616YP	1	DECAL, SHIFT
7	1736650YP	1	DECAL, BRUTE AUGER
8	1736686YP	1	DECAL, BRUTE 29"
9	1736649YP	1	DECAL, BRUTE DASH
10	1737110YP	1	DECAL, LUBRICATION
11	1737169YP	1	DECAL, MAIN DASH
12	1737172YP	1	DECAL, DANGER WARNING

Not for  
Reproduction

## Footnotes

---

**The above parts group applies to the following Mfg. Nos.:**

1695576 - Brute 13.5 TP Snowthrower (2008)

## Gear Case

NOTE: Unless noted otherwise,  
use the standard hardware torque  
specification chart.

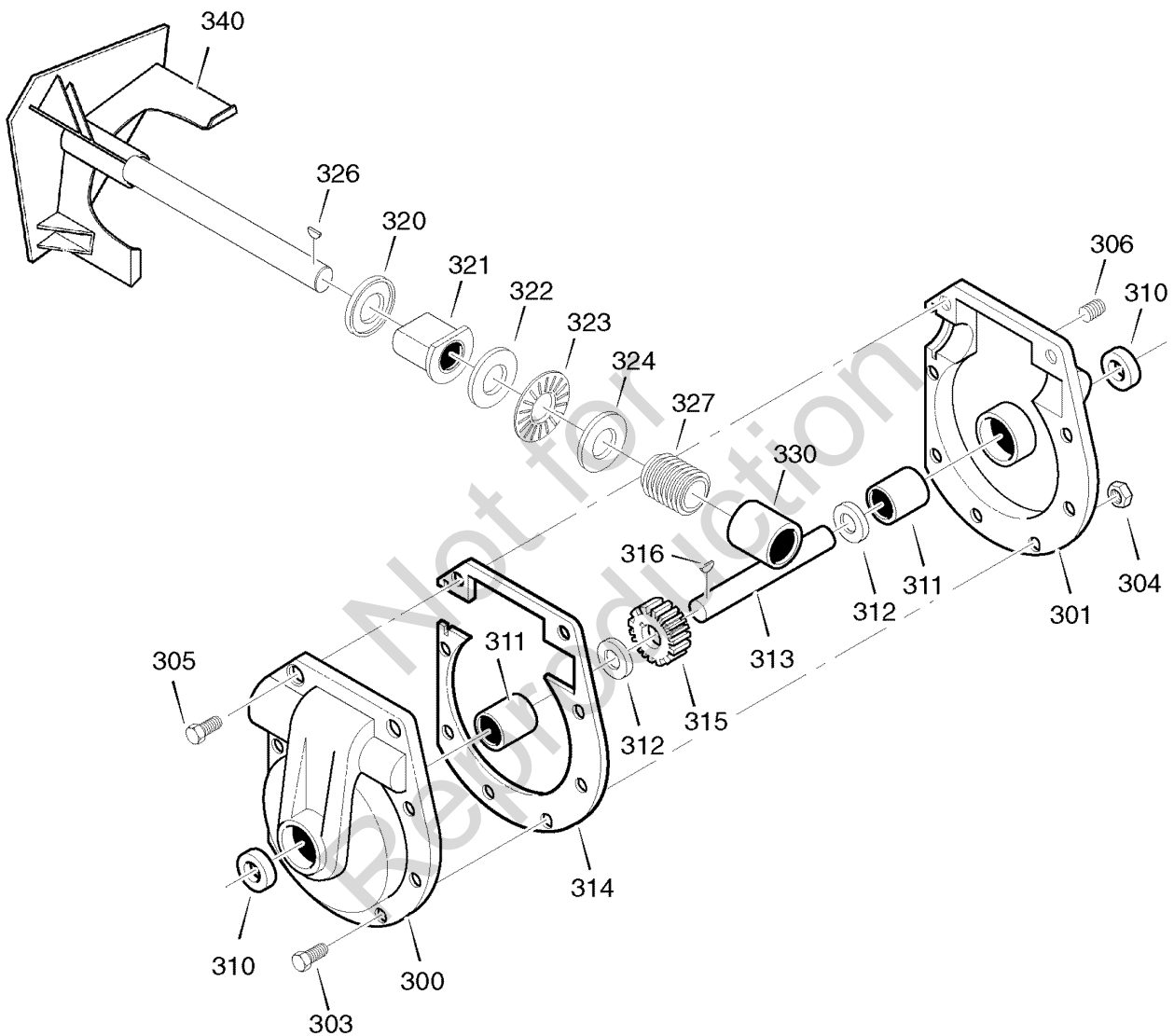

The above parts group applies to the following Mfg. Nos.:

1695576 - Brute 13.5 TP Snowthrower (2008)

## Gear Case

REF NO	PART NO.	QTY.	DESCRIPTION
300	896MA	1	CASE, GEAR, RH
301	895MA	1	CASE, GEAR, LH
303	910828MA	7	SCREW, 5/16-24 X 1.00
304	71100MA	8	NUT, 5/16-24
305	330434MA	1	SCREW, 5/16-24 X 1.50
306	53749MA	1	PLUG, PIPE 0.25-18
310	780151MA	2	SEAL, OIL
311	53743MA	2	BEARING, SLEEVE
312	53748MA	2	WASHER, FLAT
313	760528MA	1	SHAFT, AUGER OUTPUT
314	897MA	1	GASKET, GEAR BOX
315	53730MA	1	WORM GEAR
316	73905MA	2	KEY, WOODRUFF #91
320	53737MA	1	RING, QUAD 0.924 ID
321	583126MA	1	BEARING, FLANGE
322	48275MA	1	WASHER, FLAT
323	50684MA	1	BEARING, ROLLER
324	48275MA	2	WASHER, FLAT
326	50795MA	1	KEY
327	53732MA	1	WORM
330	53731MA	1	BEARING, SLEEVE
340	1740584AYP	1	IMPELLER
--	333431MA	1	10oz TUBE LUBRIPLATE

## Footnotes

**The above parts group applies to the following Mfg. Nos.:**

1695576 - Brute 13.5 TP Snowthrower (2008)

Not for  
Reproduction

# Hardware Identification & Torque Specifications

Torque Specification Chart								
FOR STANDARD METRIC MACHINE HARDWARE (Tolerance ± 20%)								
Property Class	5.6 Class 5.6		8.8 Class 8.8		10.9 Class 10.9		12.9 Class 12.9	
	in/lbs ft/lbs	Nm.	in/lbs ft/lbs	Nm.	in/lbs ft/lbs	Nm.	in/lbs ft/lbs	Nm.
M3	5.88	.56	13.44	1.28	19.2	1.80	22.92	2.15
M4	13.44	1.28	30.72	2.90	43.44	4.10	52.56	4.95
M5	26.4	2.50	60.96	5.75	5.97	8.10	7.15	9.7
M6	44.64	4.3	7.3	9.9	10.3	14	12.1	16.5
M7	5.2	7.1	12.1	16.5	16.9	23	19.9	27
M8	7.7	10.5	17.7	24	25	34	29	40
M10	15	21	35	48	50	67	59	81
M12	26	36	61	83	86.2	117	103	140
M14	42	58	101	132	136	185	162	220
M16	64	88	147	200	210	285	250	340
M18	89	121	202	275	287	390	346	470
M20	126	171	290	390	405	550	486	660
M22	169	230	390	530	559	745	656	890
M24	217	295	497	375	708	960	840	1140
M27	320	435	733	995	1032	1400	1239	1680
M30	435	590	995	1350	1401	1900	1681	2280
M33	590	800	1349	1830	1902	2580	2278	3090
M36	759	1030	1740	2360	2441	3310	2935	3980
M39	988	1340	2249	3050	3163	4290	3798	5150

The guides and ruler furnished below are designed to help you select the appropriate hardware.

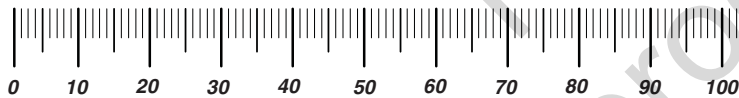

Nut, M8

Thread Diameter (mm)  
Inside Diameter (in)  
Threads per inch

Nut, 1/2-16

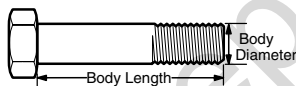

Screw, M8- 1.25 x 25

Thread Diameter (mm)  
Body Diameter  
Distance between threads (mm)  
Threads per inch  
Body Length (mm)  
Body Length (in)

Screw, 1/2- 16 x 2

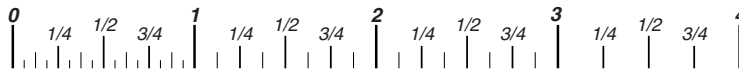

## Standard Hardware Sizing

When a washer or nut is identified as 1/2" (M8), this is the *Nominal size*, meaning the *inside diameter* is 1/2 inch (8mm metric thread diameter); if a second number is present it represents the *threads per inch* (distance between threads).

When bolt or capscrew is identified as 1/2 - 16 x 2" (M8 - 1.25 x 50 ), this means the *Nominal size*, or body diameter is 1/2 inch (8mm metric thread diameter), the second number, 16, represents the *threads per inch*, (1.25 thread diameter). The final number is the body length of the bolt or screw, 2 inches (50mm).

Torque Specification Chart						
FOR STANDARD MACHINE HARDWARE (Tolerance ± 20%)						
Hardware Grade	No Marks SAE Grade 2		SAE Grade 5		SAE Grade 8	
	in/lbs ft/lbs	Nm.	in/lbs ft/lbs	Nm.	in/lbs ft/lbs	Nm.
8-32	19	2.1	30	3.4	41	4.6
8-36	20	2.3	31	3.5	43	4.9
10-24	27	3.1	43	4.9	60	6.8
10-32	31	3.5	49	5.5	68	7.7
1/4-20	66	7.6	8	10.9	12	16.3
1/4-28	76	8.6	10	13.6	14	19.0
5/16-18	11	15.0	17	23.1	25	34.0
5/16-24	12	16.3	19	25.8	29	34.0
3/8-16	20	27.2	30	40.8	45	61.2
3/8-24	23	31.3	35	47.6	50	68.0
7/16-14	30	40.8	50	68.0	70	95.2
7/16-20	35	47.6	55	74.8	80	108.8
1/2-13	50	68.0	75	102.0	110	149.6
1/2-20	55	74.8	90	122.4	120	163.2
9/16-12	65	88.4	110	149.6	150	204.0
9/16-18	75	102.0	120	163.2	170	231.2
5/8-11	90	122.4	150	204.0	220	299.2
5/8-18	100	136	180	244.8	240	326.4
3/4-10	160	217.6	260	353.6	386	525.0
3/4-16	180	244.8	300	408.0	420	571.2
7/8-9	140	190.4	400	544.0	600	816.0
7/8-14	155	210.8	440	598.4	660	897.6
1-8	220	299.2	580	788.8	900	1,244.0
1-12	240	326.4	640	870.4	1,000	1,360.0

## NOTES

- These torque values are to be used for all hardware excluding: locknuts, self-tapping screws, thread forming screws, sheet metal screws and socket head setscrews.
- Recommended seating torque values for locknuts:
  - for prevailing torque locknuts - use 65% of grade 5 torques.
  - for flange whizlock nuts and screws - use 135% of grade 5 torques.
- Unless otherwise noted on assembly drawings, all torque values must meet this specification.

## Common Hardware Types

Hex Head Capscrew



Washer



Lockwasher

Carriage Bolt



Hex Nut

## Wrench & Fastener Size Guide

1/4" Bolt or Nut Wrench—7/16"	5/16" Bolt or Nut Wrench—1/2"	3/8" Bolt or Nut Wrench—9/16"	7/16" Bolt or Nut Wrench (Bolt)—5/8" Wrench (Nut)—11/16"	1/2" Bolt or Nut Wrench—3/4"
M6 Bolt or Nut Wrench—10mm	M8 Bolt or Nut Wrench—13mm	M10 Bolt or Nut Wrench—17mm	M12 Bolt or Nut Wrench—19mm	M14 Bolt or Nut Wrench—22mm

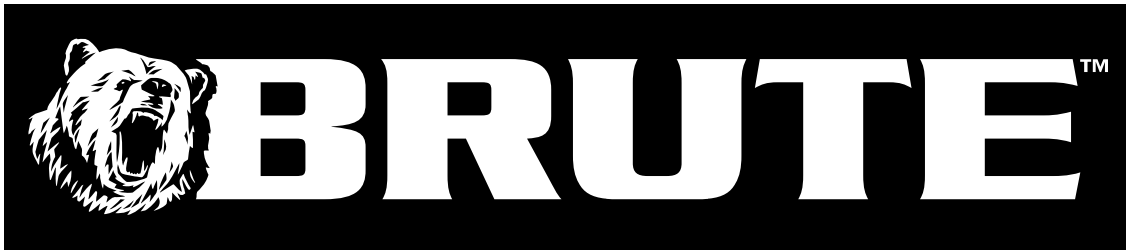

Not for  
Reproduction

**IT IS THE POLICY OF BRIGGS & STRATTON CORP. TO IMPROVE ITS PRODUCTS  
WHENEVER IT IS POSSIBLE AND PRACTICAL TO DO SO. WE RESERVE THE RIGHT TO  
MAKE CHANGES OR ADD IMPROVEMENTS AT ANY TIME WITHOUT INCURRING ANY  
OBLIGATION TO MAKE SUCH CHANGES ON PRODUCTS.**

BRUTE™ is a trademark of Briggs & Stratton Yard Power Products.

Copyright© 2008 Briggs & Stratton Power Products Group. All rights reserved. No part of this page can be reproduced or transmitted in any form by any means without the express written permission of Briggs & Stratton Power Products Group.

**Briggs & Stratton Yard Power Products Group**

3515 N. 124 Street / PO Box 702  
Wauwatosa, WI 53222 USA

[www.brutepower.com](http://www.brutepower.com)

© Copyright 2008 by Briggs & Stratton Corporation  
Milwaukee, WI, USA. All rights reserved